

ANTECH

Model 3700-B25 Waste Segregation Gamma Box Scanner

Benefits

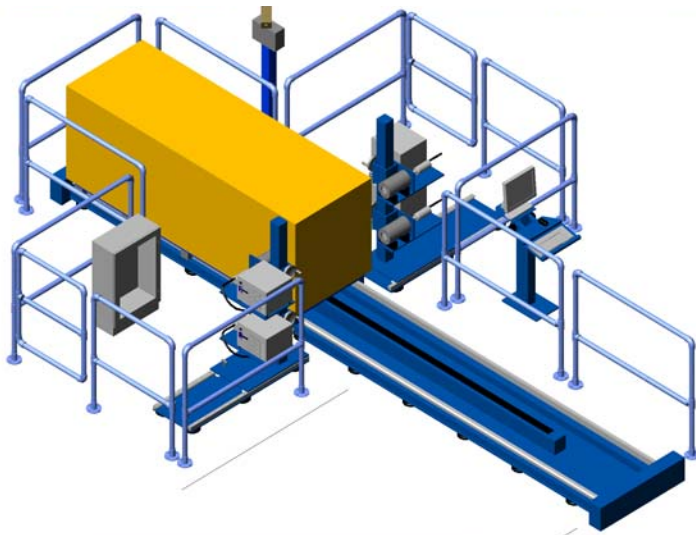

- Assays large Packages
- Multiple detector measurements detect hot spots and produce accurate container assay
- Detects matrix in-homogeneity
- High efficiency, high-resolution HPGe detectors provide high sensitivity and reliable nuclide identification
- Optional transmission sources for correction of dense matrices
- Flexible, modular design facilitates changes for different measurement conditions.
- Easily calibrated.

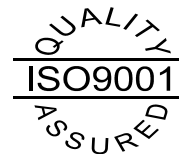

Features

- Accurately Characterises Waste using HPGe Gamma ray measurement
- Liquid Nitrogen mini-dewars or Xcooler options available for HPGe detectors
- Heights of the detectors individually adjustable.
- The counter uses ORTEC SMART-1 HPGe detectors with built in “state of health” function to provide quality assurance data throughout the measurement
- Specifically designed detector crystal dimensions to optimise the performance of the detector for the application—ORTEC profile HPGe detectors
- Data acquisition and analysis software based on ORTEC multi-detector version of Isotopic –32 V3.0 waste assay code

Description

The ANTECH 3700-B25 is a modular assay solution for the segregation of gamma-emitting waste in large containers. The principle of the measuring system is that of making possible the taking of multiple measurements of the same container from different measuring points thereby obtaining multiple estimates for the activity which is inside. These results (after correction for geometry and attenuation) may then be combined to produce a best estimate of the container total activity. "Outliers" from the container average are pointers to inconsistencies which lie in either matrix or source distribution inhomogeneity.

In operation, the container passes past the detector measurement station and stops at multiple measurement points, for example 25%, 50% and 75% of the length of the container. At each point, the multiple collimated HPGe detectors perform multiple simultaneous measurements. In a typical configuration, four detectors are positioned, two on each side of the measurement station, resulting in this example, in 12 assay measurements for the container.

ISOTOPIC V3.0, the latest waste-assay software from ORTEC manages the gathering of the multiple detector spectra and processes the result. Each detector to be used in the assay is calibrated with a simple multi-nuclide point source, and the program then extrapolates the calibration to the actual geometry and matrix conditions present at each measurement point. The results from each detector are then averaged and stored within an industry standard data base. A separate ISOTOPIC V 3.0 data sheet describes the software in more detail.

The modular nature of the 3700-B25, means that for easier or more difficult measurement situations, fewer detectors or extra detectors may be used. The beauty of the approach lies in the fact that STANDARD HPGe detectors, calibrated via simple point sources and with collimators of known dimension and materials are all that is required. This has great benefits in the cost of ownership. Replacement detectors if needed can be brought into use in minutes. The fact that ISOTOPIC calculates a complete container assay based on container physical parameters and a point source calibration for each detector, means that loss of one detector is not catastrophic to all measurement ability, and that moreover addition of a detector can be achieved in minutes.

Specification

Assay Accuracy:-

This is largely dependent on the distribution of sources inside the container and the number of measurement points, but 25-65% could be considered typical

Measurement times:-

The same considerations apply. Also, Isotopic V3.0 allows measurements to be made simultaneously or sequentially. For the example above, using 4 detectors, 2 each side of the measurement point, 3 15-minute measurements would be typical, making an overall measurement time of 45 minutes

Spectroscopy subsystems

Each standard spectroscopy sub-system (typically 4) comprises the following

- ORTEC PROFILE Series GEM HPGe detector with SMART-1 electronic package
- X-Cooler non-LN2 HPGe detector cooling