

Soil Measuring and Segregation System (SMSS)

G3107-1000

Introduction

The ANTECH Model G3107-1000 Soil Measuring and Segregation System measures and segregates soil or rubble with radiological contamination from uncontaminated soil or rubble.

It is a self-contained measuring and segregation unit that can be used in conjunction with a radiological survey to sort or segregate all potentially contaminated soil at a given site. This makes it possible to isolate soil contaminated above the assessed reporting level and to return uncontaminated soil to the site as landfill. Despite the costs of soil handling and soil monitoring, the Soil Measuring and Segregation System (SMSS) enables significant cost savings to be made by minimising the quantity of contaminated soil that must be shipped off-site for disposal.

In a single container or trailer mounted unit, the Soil Measuring and Segregation System combines a soil belt conveyor, a high efficiency shielded scintillation radiation detector, a soil diverter/sorter and all of the necessary motors, drives and control electronics to perform soil measurement and to control the soil diverter mechanism. The system can be controlled via a PC from a local control panel or over a remote link (Ethernet).

Typically, after a radiological survey has identified areas with radioactive contamination at a site, the contaminated soil is excavated using suitable earth moving and excavation equipment, such as a front-end loader. The soil is transferred to a soil-screening machine where the soil passes through a screen that removes oversized objects and stones. An output conveyor on the screening machine feeds the soil or rubble to the input hopper of the SMSS. In some circumstances a conventional soil drying or shedding plant may also be required to prepare the soil before soil measurements are performed. Note that the excavation equipment and screening machine are provided by the customer and are not part of the SMSS supply. They are standard gravel or soil handling equipment and are normally rented from local suppliers.

Soil that has been screened arrives at the input hopper of the SMSS and is levelled to a fixed depth on the conveyor belt. It then passes under the high efficiency scintillation radiation detector, which is optimised to detect particular radionuclides. Depending on the radionuclides detected and the measured activity, the microprocessor controller diverts a volume of soil on the conveyor based on the sorting criteria.

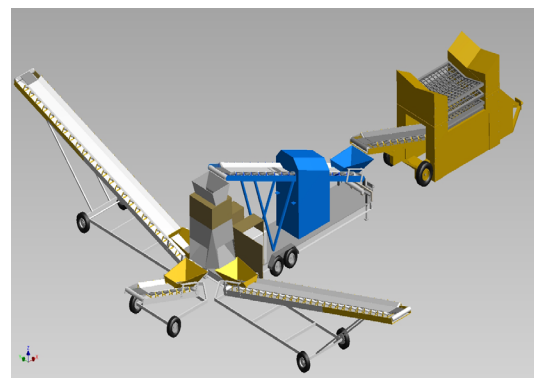

Fig 1. SMSS showing screening machine (right) and a variety of stacker conveyors (left)



Fig 2. SMSS showing the input hopper and levelling bar (right) and the 3-way diverter (left)

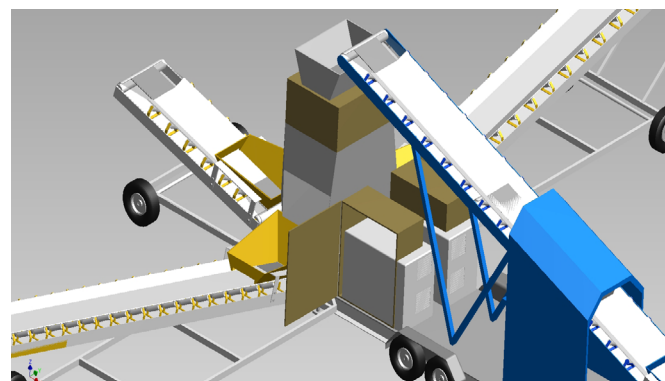

Fig 3. One 3m stacker conveyor and two 10m stacker conveyors are shown

The soil diverter or sorter comprises an input-hopper, a motor driven rotating inclined chute and 3 fixed and enclosed output chutes. The output chutes are normally aligned with the input hoppers of up to 3 conventional soil elevator or stacker conveyors (typically rented for the project from a third party supplier) which transport sorted and segregated soil to its various destinations. These destinations could include a stockpile, filling a vehicle (dump truck) or filling a 1m³ material handling bag. The separated contaminated and uncontaminated soil outputs are either stockpiled for later disposal or loaded directly into vehicles for backfill or off-site disposal (in the case of contaminated soil). The measurement cycle may be repeated to further optimise the segregation.

Features

- High efficiency NaI(Tl) scintillation Low Resolution Gamma Spectroscopy (LRGS) detector
- Shielding of detector and soil to reduce background radiation
- Variable measurement system conveyor speed
- Small radionuclide sources embedded in representative soil are used to construct a broad energy calibration
- SMSS calibration and measurement sensitivity are confirmed by Monte Carlo calculation
- 2 or 3 way soil segregation (diversion)

Benefits

- High throughput for soil measurement and segregation
- Self contained, mobile system for field operation
- Employs conventional elevator conveyors that are readily available
- Pre-processing of soil by conventional industry standard soil screening plant
- Suitable for measuring and segregating a wide range of radioactive soil contaminants
- Soil depth under the detector is controlled and, as an option, soil density can be measured
- Measurement data is archived for subsequent review
- 3 way diverter allows soil to be segregated into 3 streams:
 1. Uncontaminated soil - for return to site
 2. Low contaminated soil - for disposal at suitable level landfill
 3. Higher contaminated soil - for off-site disposal at a waste repository

Specification

Conveyor mass transfer rate	22.5 kg/s (50 lbs/s)
Soil throughput	54 cubic metres/hour (81 metric ton/hr)
Segregation criteria variable	2.7 pCi/g (0.1 - 1.83 Bq/g) (typical)
3-way soil diversion	
High efficiency scintillation detector	
Variable speed conveyor	